

Please note that the data given here has been taken from the online catalog. For comprehensive information and data, please refer to the user documentation at <http://www.download.phoenixcontact.com>. The General Terms and Conditions of Use apply to Internet downloads.

## ▶ Extract from the online catalog

Small, angled Profibus connector with screw connection and additional Pg connection



SUBCON-PLUS-PROFIB

Order No.

2708245

Ord designation

SUBCON-PLUS-PROFIB/PG/SC2

EAN

4017918960490

Pack

1 Pcs.

Customs tariff

85369010

Weight/Piece

0.0418 KG

Catalog page information

Page 470 (IF-2007)

## ▶ Product notes

WEEE/RoHS-compliant since:

10/19/2006



**IMPORTANT :** This date is valid for Customers in Germany only. Date Format is MM/DD/YYYY. Please contact your local in-country Phoenix Contact location or designated business partner for a Logistics Compliant date in your area. In order to guarantee delivery of RoHS-Compliant product, please purchase Phoenix Contact parts from authorized Phoenix Contact representatives and distributors.



---

▶ **Technical data**

---

**General data**

Nominal voltage $U_N$	60 V AC/DC
Nominal current $I_N$	1 A
Bus system	PROFIBUS up to 12 Mbit/s (terminating resistor can be connected via a slide switch)
Insertion/withdrawal cycles	> 200
Max. cable diameter	8.4 mm
Min. cable diameter	7.6 mm
SUBCON fixing screws	4-40 UNC
Tightening torque	0.4 Nm
Ambient temperature (operation)	-20 °C ... 70 °C
Housing material	ABS, metal-plated
Pin assignment	3, 5, 6, 8

**Connection data**

Connection	D-SUB connection
Number of positions	9
Type of connection	D-SUB pin strip
Connection	PCB connection
Type of connection	Screw connection
Conductor cross section solid min.	0.14 mm <sup>2</sup>
Conductor cross section solid max.	1.5 mm <sup>2</sup>
Conductor cross section stranded min.	0.14 mm <sup>2</sup>
Conductor cross section stranded max.	1 mm <sup>2</sup>
Conductor cross section AWG/kcmil min.	26
Conductor cross section AWG/kcmil max.	16
Stripping length	5 mm
Tightening torque	0.4 Nm
Connection	Programming connection
Number of positions	9
Type of connection	D-SUB female connector

## ▶ Drawings

### Dimensioned drawing

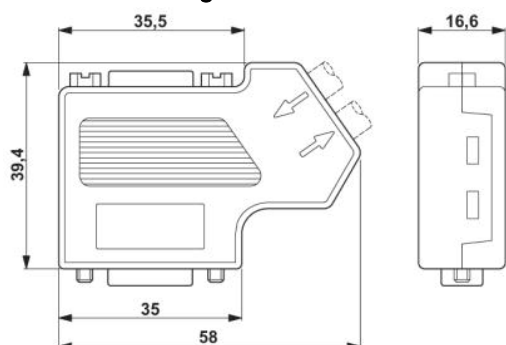

### Logo



---

## ► Accessories

---

Item	Designation	Description
<b>Cable/conductor</b>		
2744652	PSM-CABLE-PROFIB/FC	PROFIBUS cable, Fast Connect type, up to 12 Mbit/s (02YSY (ST)CY 1x2x22 AWG)
<b>Tools</b>		
2744623	PSM-STRIP-FC/PROFIB	Quick stripping tool for Profibus cable, type Fast Connect
1204384	QUICK WIREFOX 6	Stripping tool for cables with PVC insulation, stripping range: 0.08 to 6 mm <sup>2</sup> , wire cutting up to 6 mm <sup>2</sup> flexible or 4 mm <sup>2</sup> rigid

---

---

## ► Address

---

PHOENIX CONTACT GmbH & Co. KG  
Flachsmarktstr. 8  
32825 Blomberg  
Germany  
Phone +49 5235 3 00  
Fax +49 5235 3 41200  
<http://www.phoenixcontact.de>  
Phoenix Contact  
Technical modifications reserved;